

Encombrement de la gamme d'enrouleurs EC70 / EC70 Range dimensions (mm)

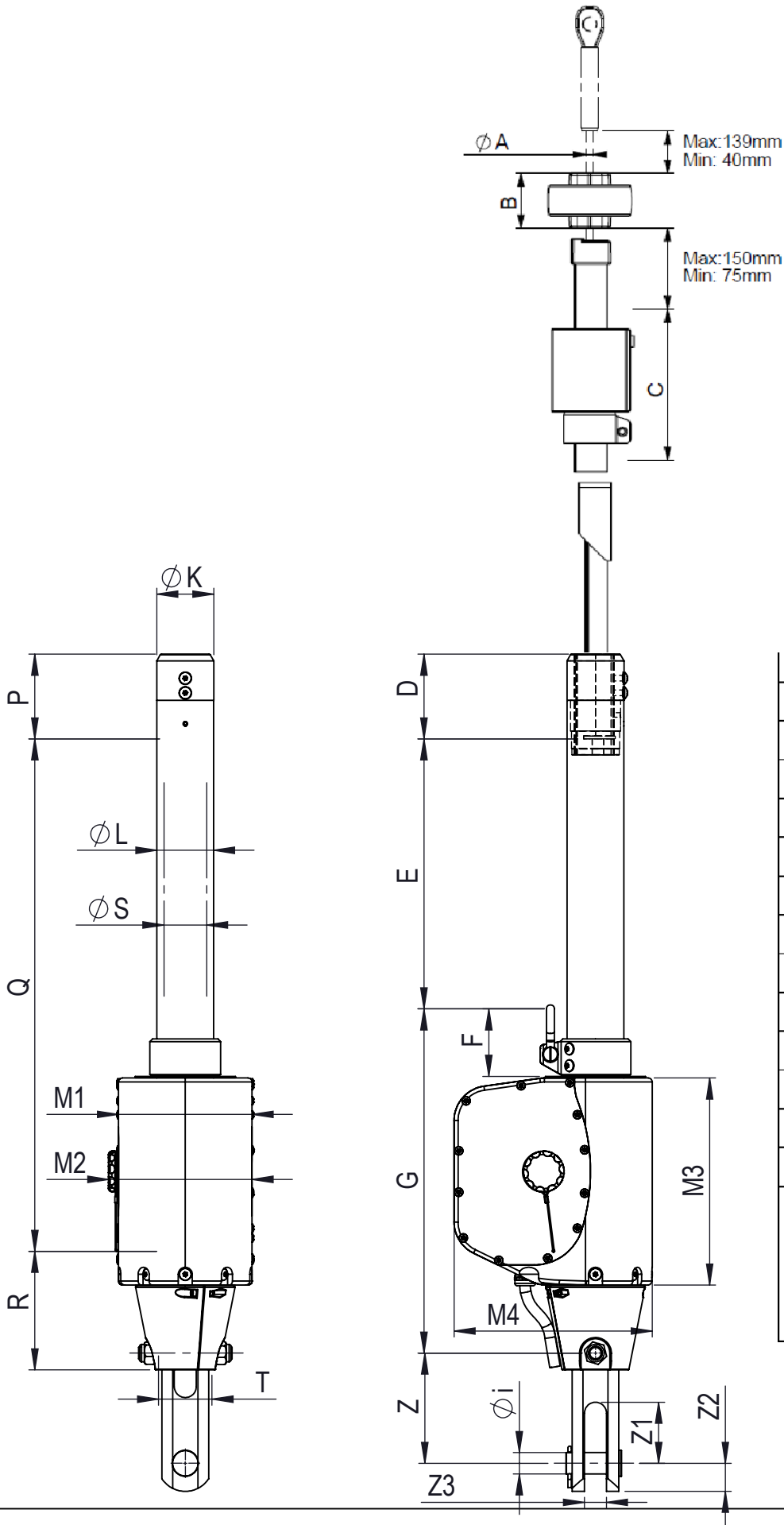

A = Ø d'étai / forestay max. (* ridoir / turnbuckle)	22 mm*
B	52
C	235
D*	127
E	404
F	101
G	515
M4	297
ØK	85
ØL	85
M1	200
M2	215
M3	310
P	127
Q	767
R	177
ØS	64
T	80
Poids hors cardan Weight without toggle	55 kg

Axe / pin Øi	Z	Z1	Z2	Z3
32	165	91	42	33