

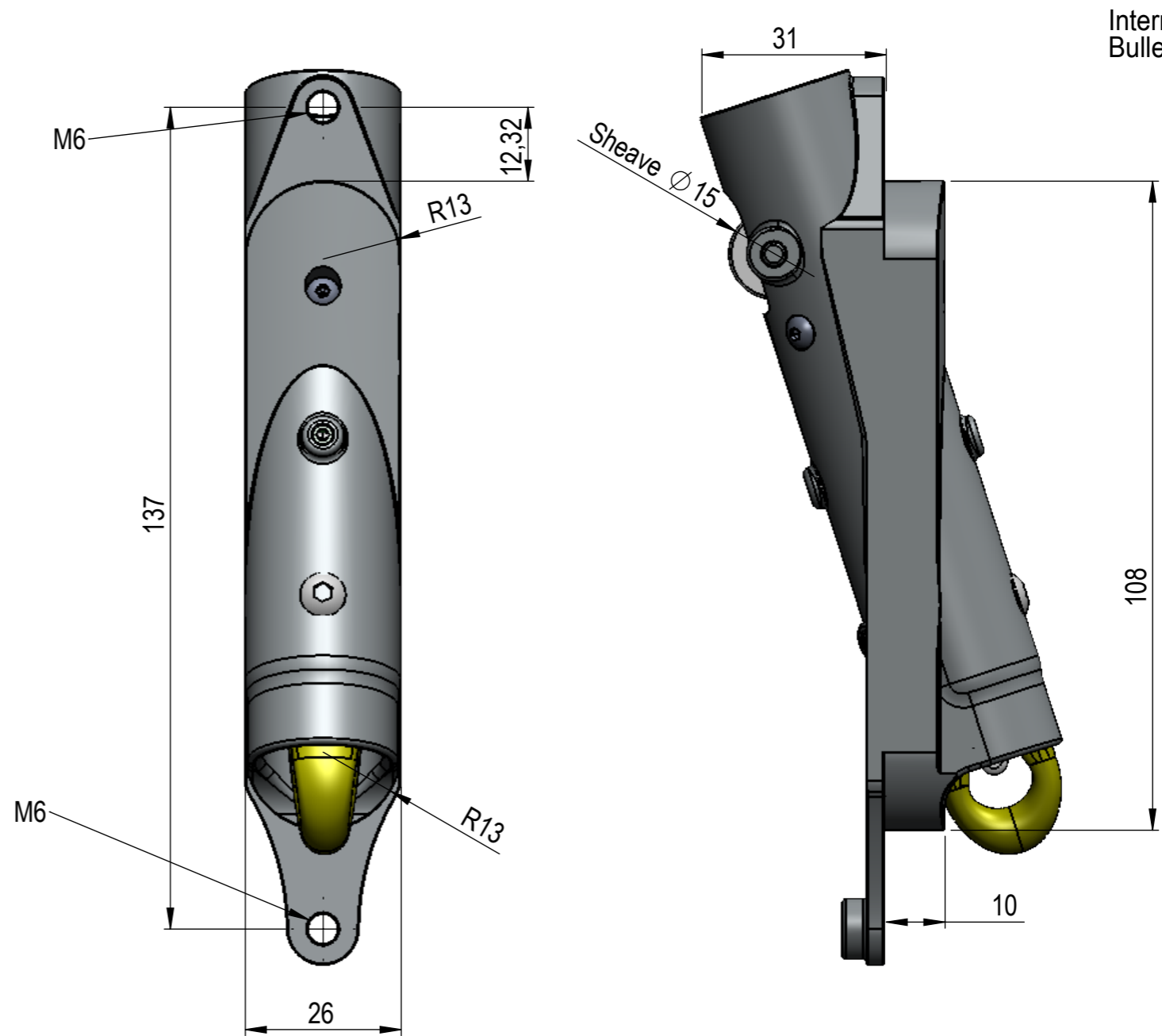

COUPE A-A 1 : 1



Poids Calc: 336.06 g

REV.	DATE	AUTEUR	APPROUVE	DESCRIPTION
A	15/10/2021	DE		NEW SPIGOT
				INTERNAL LOCK 2T SWL BEAR 10mm
				 FACNOR S.A. Parc d'Activités - B.P. 222 F-50550 SAINT-VAAST-LA-HOUGUE tel. +33 (0)2 33 88 50 22 fax. +33 (0)2 33 23 14 27
Date: 12/07/16		Tol. Gén.: +/-0.15		Etude: 2015MF0
Auteur: MFéron		Matière: ---		Usiné: Repris: Polim:
Indice: (A)		Finition: --		
Ce plan est la propriété intellectuelle de FACNOR SA. Il ne peut être divulgué à des tiers sans notre autorisation écrite, ni servir à d'autres fabrications.				